

Improving students' understanding of quantum mechanics via the Stern–Gerlach experiment

Guangtian Zhu

Department of Physics and Astronomy, University of Pittsburgh, Pittsburgh, Pennsylvania 15260

Chandralekha Singh

Department of Physics and Astronomy, University of Pittsburgh, Pittsburgh, Pennsylvania 15260

(Received 9 July 2010; accepted 13 December 2010)

The Stern–Gerlach experiment can play an important role in teaching the formalism of quantum mechanics. In the context of a finite-dimensional Hilbert space students can learn how to prepare a specific quantum state starting from an arbitrary state, issues related to the time evolution of the wave function and quantum measurement. The Stern–Gerlach experiment can also be used to teach the distinction between the physical space where the experiment is performed and the Hilbert space where the state of the system lies, and how information about the state of the system in the Hilbert space can be exploited to interpret the possible outcomes of the experiment in physical space. Students can learn the advantages of choosing an appropriate basis to make predictions about the outcomes of experiments with different arrangements of Stern–Gerlach devices. The latter can also help students understand that an ensemble of identically prepared systems is not the same as a mixture. We discuss student difficulties with the Stern–Gerlach experiment based on written tests and interviews with advanced undergraduate and graduate students in quantum mechanics courses. We also discuss preliminary data which suggest that the Quantum Interactive Learning Tutorial on the Stern–Gerlach experiment is helpful in improving student understanding of these concepts.

© 2011 American Association of Physics Teachers.

[DOI: 10.1119/1.3546093]

I. INTRODUCTION

Learning quantum mechanics is challenging.^{1–11} Investigation of student difficulties in learning quantum mechanics is a first step to developing strategies to improve their understanding.^{2,3,5,6,8,12–15} The goal of this paper is to discuss our investigation of student difficulties related to the Stern–Gerlach experiment and the development and evaluation of the Quantum Interactive Learning Tutorial (QuILT),^{16–20} which strives to help students learn about foundational issues in quantum mechanics using the Stern–Gerlach experiment.^{21–26}

In the Stern–Gerlach experiment a particle with a magnetic dipole moment is sent through an apparatus with a non-uniform magnetic field. With an appropriate gradient of the magnetic field, different components of the angular momentum in the wave function can be spatially separated by coupling them to different linear momenta. By using suitable measurement devices (for example, detectors at appropriate locations in the path of the beam), we can use the Stern–Gerlach apparatus to prepare a quantum state that is different from the initial state before the particle entered the apparatus.

The knowledge deficiencies related to the Stern–Gerlach experiment discussed in Sec. II can be broadly divided into three levels with increased difficulties in overcoming them: Lack of knowledge of relevant concepts; knowledge that cannot be interpreted correctly; and knowledge that is interpreted correctly at a basic level but cannot be used to draw inferences in specific situations.¹⁶

The Stern–Gerlach experiment tutorial, described in a later section, is based on research on student difficulties in learning quantum mechanics. It strives to build on students' prior knowledge, actively engages them in the learning process, and helps them build links between the abstract formalism and conceptual aspects of quantum physics without compro-

misging the technical content. The tutorial uses a guided inquiry method of learning, and its various sections build on what the students did in previous sections to help them develop a robust knowledge structure. As students progress through the tutorial, they first make predictions about what would happen in various situations and then are given guidance and support to reason through the situations appropriately and assimilate and accommodate productive ideas into their knowledge structure.²⁷ The tutorial is an active learning environment in which students' common difficulties are explicitly discussed. At various stages of concept development, the tutorial exploits computer-based visualization tools. Often these tools cause a cognitive conflict if students' initial prediction and their observations do not match. In that case students realize that there is an inconsistency in their reasoning. Providing students appropriate guidance and support via the guided inquiry approach used in the tutorial can be an effective strategy to help them build a robust knowledge structure.

II. INVESTIGATION OF STUDENT DIFFICULTIES

The investigation of student difficulties was done by administering written surveys to more than 200 physics graduate students and advanced undergraduate students in quantum mechanics courses at various universities and by conducting individual interviews with a subset of students. The individual interviews used a think-aloud protocol to better understand the rationale for student responses before, during, and after the development of different versions of the Stern–Gerlach tutorial and the corresponding pre-test and post-test.²⁸ During the semi-structured interviews, students were asked to verbalize their thoughts while they answered questions either before the preliminary version of the tutorial was developed or as a part of the tutorial. Students were not

interrupted unless they remained quiet for a while. In the end, we asked students for clarification of the issues they had not made clear earlier. Some of these interviews involved asking students to predict what should happen in a particular situation, having them observe what happens in a simulation, and asking them to reconcile the differences between their prediction and observation. After each individual interview with a particular version of the tutorial (along with the administered pre-test and post-test), modifications were made based on the feedback obtained from student's performance on the tutorial.

A. Difficulty in distinguishing between the physical space and Hilbert space

We can interpret the outcome of experiments performed, for example, in three-dimensional (3D) space by making connection with an abstract Hilbert space (state space) in which the state of the quantum system lies. The measured observables correspond to Hermitian operators in the Hilbert space whose eigenstates span the Hilbert space. Knowing the initial wave function and the Hamiltonian of the system allows the time evolution of the wave function to be determined and the measurement postulate can be used to determine the possible outcomes of individual measurements of an observable and its ensemble average (expectation value).

It is difficult for many students to distinguish between vectors in the 3D laboratory space and states in Hilbert space. For example, S_x , S_y , and S_z denote the orthogonal components of the spin angular momentum vector of an electron in 3D space, each of which is a physical observable that can be measured. In contrast, the Hilbert space corresponding to the spin degree of freedom for a spin-1/2 particle is two-dimensional (2D). In this Hilbert space, \hat{S}_x , \hat{S}_y , and \hat{S}_z are operators whose eigenstates span the 2D space. The eigenstates of \hat{S}_x are vectors which span the 2D space and are orthogonal to each other (but not orthogonal to the eigenstates of \hat{S}_y or \hat{S}_z). If the electron is in a magnetic field with the field gradient in the z direction in the laboratory (3D space) as in the Stern–Gerlach experiment, the magnetic field is a vector field in the 3D space but not in 2D Hilbert space. It does not make sense to compare vectors in 3D space with the vectors in the 2D space as in statements such as “the magnetic field gradient is perpendicular to the eigenstates of \hat{S}_x .” Even $L=1$ orbital angular momentum states, which are vectors in a 3D Hilbert space, differ from 3D laboratory space. These distinctions are difficult for students to make as was frequently observed in response to the survey questions and during the individual interviews. These difficulties are discussed in the following in the context of the Stern–Gerlach experiment.

For several years we have asked first year physics graduate students and advanced undergraduate students two questions related to the Stern–Gerlach experiment in written tests and interviews. These questions are the first two questions in the Appendix. In one version of these questions, neutral silver atoms were replaced with electrons and students were told to ignore the Lorentz force on the electron.

In Question 1 students need to realize that the magnetic field gradient in the $-z$ direction imparts a spin-dependent momentum to the particle and two spots would be observed on the phosphor screen due to the splitting of the beam along the z direction due to the particle's spin components corre-

sponding to the $|\uparrow\rangle_z$ and $|\downarrow\rangle_z$ states. Responses in which students noted that there will be a splitting along the z direction were considered correct even if they did not explain their reasoning. Only 41% of the more than 200 graduate students from different universities enrolled in a quantum mechanics course gave the correct response. This question was a part of a survey at the beginning of graduate level quantum mechanics instruction. Many students thought that there would only be a single spot on the phosphor screen. During the interviews conducted with a subset of these students, they were often confused about the origin of the spin-dependent momentum imparted to the particle.

The same question was given to 35 undergraduate students in two different classes at the University of Pittsburgh immediately after instruction in the Stern–Gerlach experiment. These students obtained 80%. Many of the first year graduate students in the graduate level quantum mechanics course who took the survey had forgotten about the Stern–Gerlach experiment. Discussions with some of the graduate students suggests that they had learned about the Stern–Gerlach experiment only in the context of a modern physics course which was qualitative.

Question 2 is challenging because students have to realize that because the magnetic field gradient is in the $-x$ direction, the basis must be chosen to be the eigenstates of \hat{S}_x to readily analyze how the Stern–Gerlach apparatus will affect the spin state. The initial state, which is an eigenstate of \hat{S}_z , $|\uparrow\rangle_z$, can be written as a linear superposition of the eigenstates of \hat{S}_x , that is, $|\uparrow\rangle_z = (|\uparrow\rangle_x + |\downarrow\rangle_x) / \sqrt{2}$. The magnetic field gradient in the $-x$ direction will couple the $|\uparrow\rangle_x$ and $|\downarrow\rangle_x$ components in the incoming spin state $|\uparrow\rangle_z$ with oppositely directed x -components of the linear momentum and will cause two spots on the phosphor screen separated along the x axis.

Only 23% of the more than 200 graduate students in the same survey gave the correct response. The performance of the same 35 undergraduate students discussed previously from two different classes who were given this question immediately after traditional instruction in the Stern–Gerlach experiment was only somewhat better (39%). In some of the undergraduate student interviews, we asked students to predict the outcome of these experiments and then showed them what happens in a simulation and asked them to reconcile the differences between the observation and prediction. This task turned out to be extremely difficult. The most common difficulty in Question 2 was believing that because the spin state is $|\uparrow\rangle_z$, there should not be any splitting as shown in Fig. 1.

Many students explained their reasoning by stating that because the magnetic field gradient is in the $-x$ direction but the spin state is along the z direction, the magnetic field and the spin state are orthogonal to each other, and therefore, there cannot be any splitting of the beam. Student responses suggest that they were incorrectly connecting the gradient of the magnetic field in the 3D space with the “direction” of state vectors in Hilbert space. Several students drew monotonically increasing curves (see Fig. 2) and some of them incorrectly believed that the spin state in this situation would be pulled in one direction because the magnetic field gradient is in a certain direction (see Fig. 2). Asking the students whether they could consider a basis that might be more appropriate was rarely helpful.

One student drew the diagram shown in Fig. 3 and de-

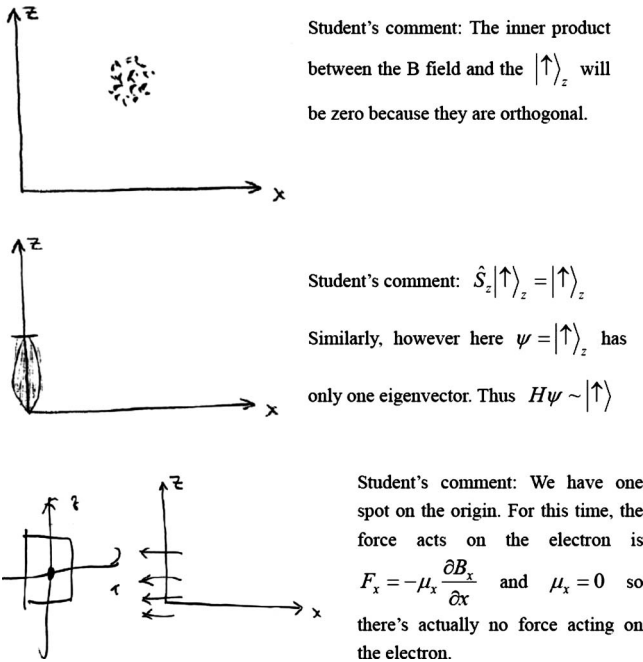

Fig. 1. Three sample responses in which students provided incorrect explanations for why there should be one spot instead of two for Question 2. The students' comments for each figure are typed for clarity.

scribed Larmor precession of a spin, but did not mention anything about the spin-dependent momentum imparted to the particle due to the non-uniform magnetic field as in the Stern–Gerlach experiment. Written responses and interviews suggest that many students were unclear about the fact that in a uniform external magnetic field, the spin will only precess (if not in a stationary state) but in a non-uniform magnetic field as in the Stern–Gerlach experiment, there will be a spin-dependent momentum imparted to the particle that spatially separates the components of the spin angular momentum under suitable conditions.

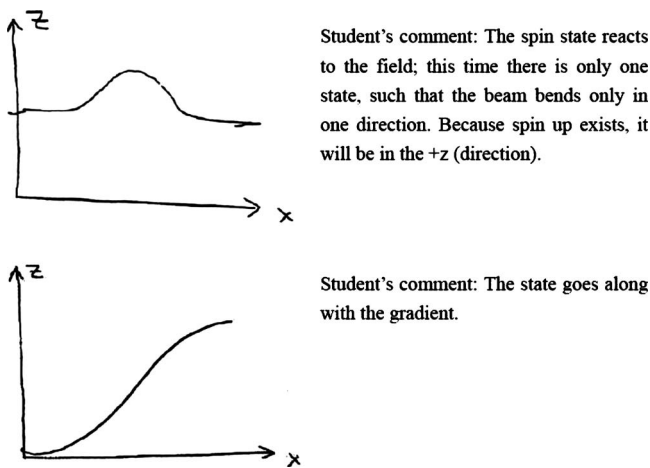

Fig. 2. Two sample responses in which students provided incorrect explanations for why the state/beam will bend as shown in response to the magnetic field gradient in Question 2.

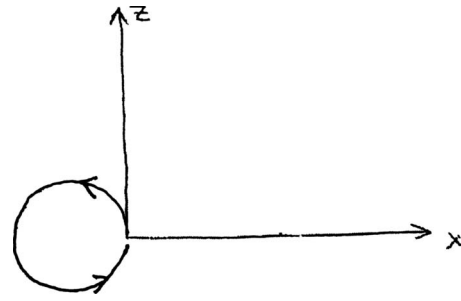

Fig. 3. A diagram drawn by a student showing the Larmor precession of spin in response to Question 2.

B. Larmor precession of spin involves precession in physical space

The student who drew Fig. 3 incorrectly believed that spin is due to motion in real space. When he was reminded that the question was not about the dynamics (as suggested by the arrows drawn by the student to show the direction of precession) but about the pattern observed on the screen, he incorrectly claimed that the pattern on the screen would be a circle due to the precession of the spin in the magnetic field. Similarly, we found that many students have difficulty realizing that spin is not an orbital degree of freedom, and there are two spots on the screen in Questions 1 and 2 because of the coupling of the spin degree of freedom with the orbital degree of freedom.

C. Difficulty with state preparation

We found that students have difficulty with the preparation of a specific quantum state even in a 2D Hilbert space. Students were asked questions related to state preparation using the Stern–Gerlach apparatus in both written tests and interviews, as for example, in Question 8.

A possible correct response would be to pass the initial beam through a Stern–Gerlach apparatus with a magnetic field gradient in the x or y direction and block one component of the spatially separated beam that comes out of the apparatus before passing it through another Stern–Gerlach apparatus with its field gradient in the z direction. We can then block the $|\uparrow\rangle_z$ component with a detector and obtain a beam in the spin state $|\downarrow\rangle_z$.

Out of 17 first year graduate students enrolled in a quantum mechanics course who had instruction in the Stern–Gerlach experiment, 82% provided the correct response to Question 8. Only 30% of undergraduate students after traditional instruction provided the correct response. Interviews suggest that students had much difficulty thinking about how to choose an appropriate basis to facilitate the analysis of what should happen after particles in a given spin state were sent through a Stern–Gerlach apparatus with a particular magnetic field gradient.

D. Differentiating between a superposition and a mixture

We also asked students to think of a strategy to distinguish between a superposition in which all particles are in state $(|\uparrow\rangle_z + |\downarrow\rangle_z)/\sqrt{2}$ from a mixture in which half of the particles are in state $|\uparrow\rangle_z$ and the other half are in state $|\downarrow\rangle_z$ as in Question 9.

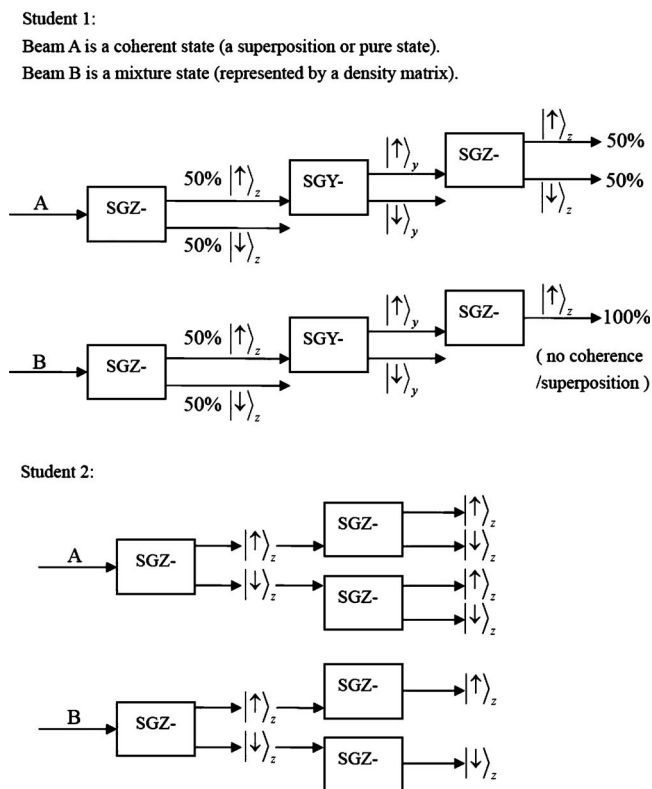

Fig. 4. Examples of two graduate students' responses to Question 9.

This question was very difficult for most students. One strategy for distinguishing between the superposition and the mixture is to pass each of them one at a time through a Stern–Gerlach apparatus with the field gradient in the $-x$ direction. Because $(|\uparrow\rangle_z + |\downarrow\rangle_z)/\sqrt{2}$ is $|\uparrow\rangle_x$, particles in this state will completely deflect upward (go out through the upper channel) after passing through a Stern–Gerlach apparatus with a negative x gradient. In contrast, the equal mixture of $|\uparrow\rangle_z$ and $|\downarrow\rangle_z$ has an equal probability of registering at the detectors in the lower and upper channels after passing through a Stern–Gerlach apparatus with a negative x gradient because these states can be written as $(|\uparrow\rangle_x \pm |\downarrow\rangle_x)/\sqrt{2}$ in terms of the eigenstates of \hat{S}_x and will become spatially separated after passing through the apparatus.

Out of 17 first year graduate students enrolled in quantum mechanics who had instruction in the Stern–Gerlach experiment, only 24% responded correctly to this question. In an undergraduate course in which the instructor had discussed similar problems with students before giving them this question, 31% responded correctly after traditional instruction. One student incorrectly noted: “Since the probability for an atom in the beam A to be in either state $|\uparrow\rangle_z$ or $|\downarrow\rangle_z$ is 1/2, I can’t distinguish it from B.” Another incorrect response emphasized differences in the coupling of the spin angular momentum with the linear momentum: “The atoms in beam A will have their spin coupled to the z -component of their momentum. The other beams’ atoms, however, will not have P_z coupled to S_z .” Some students who believed that it is possible to separate a mixture from a superposition state using a Stern–Gerlach apparatus provided incorrect reasoning. Figure 4 provides two such examples in which students first let

each of the beams pass through a Stern–Gerlach apparatus with a magnetic field gradient in the z direction.

III. QUILT: WARM-UP AND HOMEWORK

As discussed in Sec. I, the tutorial builds on the prior knowledge of students and was developed based on the difficulties found by written surveys and interviews. The development of QuILT went through a cyclical iterative process which includes the following stages: Development of the preliminary version based on a theoretical analysis of the underlying knowledge structure and research on student difficulties, implementation and evaluation of QuILT by administering it individually to students, determining its impact on student learning and assessing what difficulties remained, and refinements and modifications based on the feedback from the implementation and evaluation. When we found that QuILT worked well for individual students and the post-test performance after using the tutorial was significantly improved compared to the pre-test performance, it was administered in undergraduate quantum mechanics classes after traditional instruction on the Stern–Gerlach experiment.

The tutorial begins with warm-up exercises and includes homework questions that students work on before and after working on the tutorial. The warm-up exercises discuss preliminary issues such as why there is only a torque on the magnetic dipole in a uniform magnetic field, but why there is a “force” in a non-uniform magnetic field (or more precisely, a momentum is imparted to the particle due to its angular momentum). It also helps students understand that the zero divergence of the magnetic field implies that the gradient of the magnetic field cannot be nonzero in only one direction, and if we choose the gradient to be nonzero in two orthogonal directions and also apply a strong uniform magnetic field in one of those directions, the Larmor precession will make the average force in one of the directions zero. In this way we can focus only on the magnetic field gradient in a particular direction for determining its effect on the spin state after passing through the Stern–Gerlach apparatus.

The warm-up exercise also discusses how the wave function of the quantum system includes both the spatial and spin parts of the wave function. For simplicity, students are asked to assume that before passing through a Stern–Gerlach apparatus with the field gradient in the z direction at time $t=0$, the spatial wave function $\psi(x, y, z)$ is a Gaussian localized near $(x, y, z)=(0, 0, 0)$ and the spatial and spin parts of the wave function are not entangled. Therefore, the wave function $\Psi(t=0)$ can be written as a product of the spatial part ψ and the spin part χ : $\Psi(t=0) = \psi(x, y, z)|\chi\rangle$. Students are guided by a series of questions including the following:

A silver atom in the state $\Psi(t=0) = \psi(x, y, z)(a|\uparrow\rangle_z + b|\downarrow\rangle_z)$ passes through a Stern–Gerlach apparatus with a non-uniform magnetic field $\vec{B} = C_0 z \hat{k}$ from time $t=0$ to $t=T$. Which one of the following is the wave function at a time $t=T$ when the atom just exits the magnetic field? Assume that the atom is in the apparatus for a short time so that there is no change in its spatial coordinates. (Hint: The time development of each stationary state is by an appropriate term of the type $e^{\pm iE_{\pm}t/\hbar}$.)

- $\Psi(T) = a\phi_+|\uparrow\rangle_z + b\phi_-|\downarrow\rangle_z$ where $\phi_{\pm}(x, y, z) = e^{\pm iC_0\gamma z T/2}\psi(x, y, z)$.
- $\Psi(T) = \phi_+(x, y, z)(a|\uparrow\rangle_z + b|\downarrow\rangle_z)$.

- (c) $\Psi(T) = \psi(x, y, z)(a|\uparrow\rangle_z + b|\downarrow\rangle_z)$.
 (d) None of the above.

Students also learn that in the wave function at time T , $\Psi(T) = a\phi_+|\uparrow\rangle_z + b\phi_-|\downarrow\rangle_z$, the spatial and spin parts of the wave functions are “entangled” because spin and orbit cannot be factorized. Thus, measurement of the orbital degrees of freedom is linked to spin and vice versa. Students are told that the spatial part of the wave function $\psi(x, y, z)$ will not be mentioned explicitly in the remaining part of the tutorial. However, they should understand that a Stern–Gerlach apparatus entangles the spatial and spin parts of the wave function.

The warm-up helps students understand how the coupling of the orbital and spin degrees of freedom causes the spatial separation of various spin components of the wave function. In the warm-up, students also learn that although the different components of spin may become spatially separated after passing through a Stern–Gerlach apparatus, the wave function will remain in a superposition of different spin states until a measurement is made, for example, by placing a detector in an appropriate location. For example, the wave function for a spin-1/2 particle can become spatially separated after passing through certain orientations of a Stern–Gerlach apparatus. If a detector placed after the Stern–Gerlach apparatus at an appropriate location detects a particle (clicks), the wave function collapses to one state compared to when the detector does not click (in which case we have prepared the particles in a definite spin state).

In the tutorial warm-up (which students are expected to complete at their own pace after traditional instruction but before working on the tutorial) students also learn about issues related to distinguishing between vectors in 3D physical space and state vectors in Hilbert space. In this context they learn that the magnetic field gradient in the z direction is not perpendicular to a spin state in the Hilbert space, a common student misconception. Students also learn why choosing a particular basis is useful when analyzing particles going through a Stern–Gerlach apparatus with a particular magnetic field gradient. The tutorial warm-up also helps reduce confusion about the x , y , and z labels used to denote the orthogonal components of a vector, for example, in classical mechanics, and the eigenstates of different components of the spin operator (\hat{S}_x , \hat{S}_y , and \hat{S}_z), which are not orthogonal to each other.

The homework extends what students have learned in the tutorial and also focuses further on issues related to quantum measurement and state preparation by a Stern–Gerlach apparatus. One common difficulty is that students often believe that a particle passing through a Stern–Gerlach apparatus is equivalent to the measurement of particle’s spin angular momentum. These issues are clarified in the homework.

IV. STERN–GERLACH TUTORIAL

As noted, the tutorial uses a guided inquiry-based approach in which various concepts build on each other gradually. It employs visualization tools to help students build intuition about concepts related to the Stern–Gerlach experiment. The SPINS program²⁹ was adapted for the tutorial. This program extends David McIntyre’s open source Java applet³⁰ by allowing simulated experiments to be stored and run easily.



Fig. 5. Set up for a guided example in the tutorial.

An effective strategy to help students build a robust knowledge structure is by causing a cognitive conflict in students’ minds such that the students realize that there is an inconsistency in their reasoning and then providing them appropriate guidance and support. After predicting what they expect in various situations, students are asked in the tutorial to check their predictions using simulations. If the prediction and observations do not match, students reach a state of cognitive conflict. At that point the tutorial provides them guidance to help them reconcile the difference between their predictions and observations (Fig. 5).

The tutorial helps students learn about issues related to measurement, preparation of a desired quantum state, for example, $|\uparrow\rangle_x$, starting with an arbitrary initial state, the time evolution of the wave function, the difference between superposition and mixture, the difference between physical space and Hilbert space, the importance of choosing an appropriate basis to analyze what would happen in a particular situation. Figure 6 shows a simulation from the SPINS program²⁹ that students use after their initial prediction related to a question that shows that we can input $|\uparrow\rangle_z$ and obtain $|\downarrow\rangle_z$ (Fig. 5).

To help students understand that it is possible to pass the state $|\uparrow\rangle_z$ through a Stern–Gerlach apparatus to prepare the orthogonal state $|\downarrow\rangle_z$, the tutorial also draws an analogy with the photon polarization states. Students learn that if atoms in the state $|\uparrow\rangle_z$ pass through a Stern–Gerlach apparatus with the gradient in the z direction, the state $|\downarrow\rangle_z$ will not be obtained. However, $|\downarrow\rangle_z$ is obtained in the simulation shown in Fig. 6 because we have inserted a Stern–Gerlach apparatus

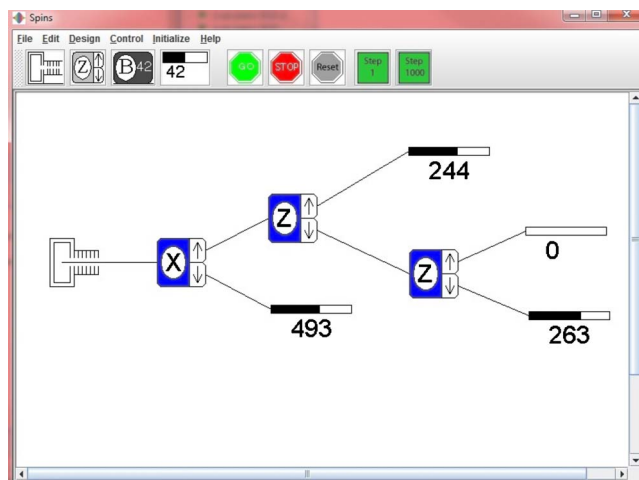

Fig. 6. A snapshot of the simulation constructed from the SPINS program (Ref. 29) used by students that shows that one can input $|\uparrow\rangle_z$ and obtain $|\downarrow\rangle_z$. The snapshot shows 493 particles are registered in the detector right after passing through the Stern–Gerlach apparatus with the magnetic field gradient in the negative x direction, 244 particles are registered in the detector right after the first Stern–Gerlach apparatus with the magnetic field gradient in the negative z direction, and 263 particles are registered in the detector after the second Stern–Gerlach apparatus with the magnetic field gradient in the negative z direction.

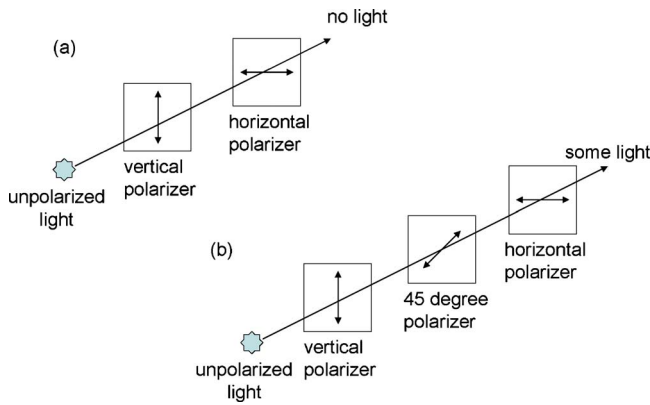

Fig. 7. Analogy between spin states and photon polarization states.

with the field gradient in the negative x -direction at an intermediate stage. Students consider the analogy with vertically polarized light passing directly through a horizontal polarizer [see Fig. 7(a)] compared to passing first through a polarizer at 45° followed by a horizontal polarizer [see Fig. 7(b)]. There is no light at the output if vertically polarized light passes directly through a horizontal polarizer. In contrast, if the polarizer at 45° is present, light becomes polarized at 45° after the 45° polarizer, which is a linear superposition of horizontal and vertical polarization. Therefore, some light comes out through the horizontal polarizer placed after the 45° polarizer. Because the experiment with the polarizers (in the context of a photon beam) is familiar to students from introductory physics, this analogy can help students learn about the Stern–Gerlach experiment in a familiar context.

While working through the tutorial, students are asked a guided sequence of questions to help them distinguish between superposition and mixture. The tutorial presents a common incorrect point of view on the issue dealing with superposition and mixture. Then, the students are given an opportunity to check their predictions using simulations and reconcile the differences using more guidance and support as needed. Further questions are given to students to help them understand the difference between a pure state and a mixture by reinforcing the analogy between the spin states of electrons and the polarization states of photons. The guidance to students is decreased as students make progress through the tutorial. In the later part of the tutorial, students are given open-ended questions such as the following.

The following questions relate to the simulation “unknown state.” Run the simulation “unknown state” first. Then answer the following questions.

(a) Write down at least three different possible spin states of the incoming particles that will show the behavior seen in the simulation. The incoming particles need not necessarily have identical spin states (can be a mixture). Explain your reasoning for your choices.

(b) Choose two of the different possible spin states you predicted for the simulation you saw. Now come up with some simulations using Stern–Gerlach apparatus that would distinguish between these two possible spin states. You can choose one or more Stern–Gerlach apparatus to find out which of the two spin states it is. Share your set-up with others in your class.

Table I. Scores of the pre-test (after traditional instruction but before the tutorial) and post-test (after the tutorial). The total number of students including both classes who answered each question is given in parenthesis. Each student in a class of 22 students was given the same pre-test and post-test. The pre-test and post-test were mixed for the second class of 13 students as discussed in the text.

Question	Pre-test score (%) (number of students)	Post-test score (%) (number of students)
1	80 (35)	81 (13)
2	39 (35)	77 (13)
3	34 (30)	80 (5)
4	47 (30)	80 (5)
5	60 (5)	93 (30)
6	0 (5)	92 (30)
7	0 (5)	92 (30)
8	30 (5)	100 (8)
9	31 (8)	70 (5)

V. PRE- AND POST-TEST DATA FOR THE STERN–GERLACH TUTORIAL

We conducted preliminary evaluations of the tutorial in two junior-senior level classes. The two classes were taught by different instructors. In both classes students first received traditional instruction on the Stern–Gerlach experiment, took a pre-test, worked on the tutorial and then took a post-test in the following class period. The test questions are given in the Appendix. The first class with 22 students was given Questions 1–4 in the pre-test and Questions 5–7 on the post-test. The average pre-test score for this class was 52% and the average post-test score was 92%.

For the second class with 13 students we designed two versions of a test to assess student learning. Version A contained Questions 1, 2, 3, 4, and 9 and version B had Questions 1, 2, 5, 6, 7, and 8. Students in the second class were randomly administered either version A or version B of the test as the pre-test after traditional instruction. Each student was then given the version of the test he/she had not taken as the post-test after working on the tutorial. In particular, eight students in the second class were administered version A as the pre-test (and version B as the post-test) and the other five students were given version B as the pre-test (and version A as the post-test). The average pre-test score for the second class was 37%, and the average post-test score was 84%. The average pre-test and post-test performance on each question combining the two groups of students is given in Table I. Except for Question 1, on which students performed reasonably well even on the pre-test (after traditional instruction), student performance improved on all the other questions after working on the tutorial.

In Table I the improved performance on Question 2 discussed in Sec. II (in which students were asked about the pattern on the screen when neutral silver atoms in the spin state $|\uparrow\rangle_z$ were sent through a Stern–Gerlach apparatus with the field gradient in the negative x -direction) suggests that students were much more likely to correctly predict the type of pattern that forms on the screen when particles in a particular spin state pass through a Stern–Gerlach apparatus with a particular field gradient. Individual discussions with some students suggest that after the tutorial students had a good understanding of how to choose an appropriate basis.

Some of them were able to write the initial spin state in an appropriate basis, and differentiate between the spin states and the direction of the magnetic field gradient. In particular, some students during the discussions explicitly noted that the eigenstates of the z -component of spin are orthogonal to each other, but not orthogonal to the magnetic field gradient in the x direction. In Question 3 many students realized after the tutorial that the superposition of the eigenstates of the z -component of spin given is actually an eigenstate of the x -component of spin so all the particles will be deflected upward and nothing will be detected by the detector shown in the setup.

Students also performed reasonably well after the tutorial on questions where the particle went through several Stern–Gerlach devices in tandem (for example, Questions 4 and 6). Question 4 (which is about preparing a quantum state orthogonal to the initial state, similar to Question 8) requires students to understand that half of the atoms will be blocked by the detector immediately after the Stern–Gerlach apparatus with the field gradient in the negative y -direction. Then the $|\uparrow\rangle_y$ state passing through the Stern–Gerlach apparatus with the field gradient in the negative z -direction will spatially separate the spin state such that there is equal probability of the up detector at the end collecting an atom in spin state $|\downarrow\rangle_z$. In Question 4 the fraction of the initial atoms detected in the “up” detector or collected for another experiment is 25% each. In Table I we see that students are better able to prepare a particular spin state starting from another spin state using the Stern–Gerlach apparatus in the open-ended Question 8.

In Question 6, students have to realize that after the initial spin state $|\uparrow\rangle_z$ passes through the Stern–Gerlach apparatus with the field gradient in the negative z -direction, none of the atoms will register in the first detector. All the atoms in the $|\uparrow\rangle_z$ state will enter the Stern–Gerlach apparatus with the field gradient in the negative x -direction. Since we have $|\uparrow\rangle_z = (|\uparrow\rangle_x + |\downarrow\rangle_x) / \sqrt{2}$, there is 50% probability of the second detector clicking and 50% probability of preparing an atom in spin state $|\downarrow\rangle_x$. Now when an atom in the spin state $|\downarrow\rangle_x = (|\uparrow\rangle_z - |\downarrow\rangle_z) / \sqrt{2}$ passes through the last Stern–Gerlach apparatus with the field gradient in the positive z -direction, the probability of the down detector clicking is 50% (which is the same as the probability of preparing an atom in the $|\downarrow\rangle_z$ state). Hence, the total probability that a particle will be transmitted through all three Stern–Gerlach apparatuses is $50\% \times 50\% = 25\%$.

Question 7 (in which the incoming state was a general state) was quite challenging for students after traditional instruction alone. One way to answer this question is to write the initial spin state $|\chi\rangle = a|\uparrow\rangle_z + b|\downarrow\rangle_z$ as an eigenstate of \hat{S}_x since the Stern–Gerlach apparatus has the field gradient in the negative x -direction. Since $|\uparrow\rangle_z = (|\uparrow\rangle_x + |\downarrow\rangle_x) / \sqrt{2}$ and $|\downarrow\rangle_z = (|\uparrow\rangle_x - |\downarrow\rangle_x) / \sqrt{2}$, it is possible to infer that the fraction of the initial silver atoms still available in the $|\downarrow\rangle_x$ state after passing through the Stern–Gerlach apparatus is $|a-b|^2/2$. Student performance after the tutorial on Question 7 further suggests that they had a better understanding of how to choose a convenient basis to analyze the output of a Stern–Gerlach apparatus than before the tutorial. Moreover, the improved performance on Questions 5 and 9 (in which the correct answer to Question 5 is (D) and Question 9 discussed earlier in Sec. II was open-ended) suggest that students had a

better understanding of how a superposition of spin states and a mixture can be differentiated using Stern–Gerlach devices.

In addition to the pre- and post-tests, students who had used the tutorial were asked the following two questions in the *second* semester junior-senior level undergraduate quantum mechanics course. The goal was to investigate if students can distinguish the two situations, one of which involves a superposition and another a mixture when the magnetic field gradient was explicitly provided (this question is different from Question 9 on the post-test given to students 5 months earlier in which students had to come up with their own arrangement of the Stern–Gerlach apparatus).

Suppose a beam consists of silver atoms in the state $(|\uparrow\rangle_z + |\downarrow\rangle_z) / \sqrt{2}$. The beam passes through a Stern–Gerlach apparatus with the magnetic field gradient in the x -direction. How many detector(s) are sufficient to detect all the silver atoms passing through the Stern–Gerlach apparatus? Draw a diagram and explain your reasoning.

Suppose a beam consists of an unpolarized mixture of silver atoms in which half of the silver atoms are in state $|\uparrow\rangle_z$ and half are in state $|\downarrow\rangle_z$. The beam passes through a Stern–Gerlach apparatus with the magnetic field gradient in the x -direction. How many detector(s) are sufficient to detect all the silver atoms passing through the Stern–Gerlach apparatus? Draw a diagram and explain your reasoning.

Eight out of nine undergraduate students who answered these two questions at the end of the second semester provided the correct response for both questions. It is encouraging that the students had retained these concepts a full semester after working on the tutorial.

VI. SUMMARY

We have investigated students’ difficulties with quantum mechanics formalism via the Stern–Gerlach experiment and used the findings as a guide to develop a tutorial to help students learn about the fundamentals of quantum mechanics using this experiment. The Stern–Gerlach experiment can be used to teach many aspects of quantum mechanics effectively including issues related to measurement, importance of choosing a particular basis, differentiation between Hilbert space and real space, and the difference between a pure linear superposition of states vs. a mixture. Preliminary evaluation suggests that the tutorial is effective in improving students’ understanding of quantum mechanics concepts in the context of Stern–Gerlach experiment.

ACKNOWLEDGMENTS

We thank the instructors for administering the surveys and tutorials in their classes. We are grateful to NSF for Award Nos. PHY-0653129 and 055434.

APPENDIX: THE PRE-/POST-TEST QUESTIONS

Some of the following questions (or similar questions) were also used during the investigation of students’ difficulties at various stages of the development of the tutorial.

The following information is provided in the pre-/post-test.

Figure 8 shows the pictorial representations used for a Stern–Gerlach apparatus. If an atom in state $|\uparrow\rangle_z$ (or $|\downarrow\rangle_z$) passes through a Stern–Gerlach apparatus with the field gra-

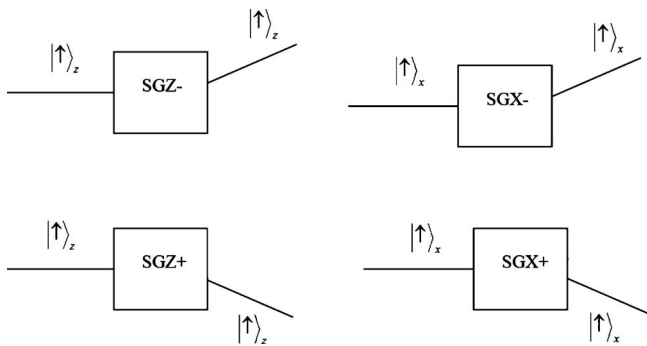

Fig. 8. Pictorial representations of a Stern–Gerlach apparatus.

dent in the negative z direction, it will be deflected in the $+z$ (or $-z$) direction. If an atom in state $|\uparrow\rangle_z$ (or $|\downarrow\rangle_z$) passes through a Stern–Gerlach apparatus with the field gradient in the positive z direction, it will be deflected in the $-z$ (or $+z$) direction. Similarly, if an atom in state $|\uparrow\rangle_x$ passes through a Stern–Gerlach apparatus with the field gradient in the negative x (or positive x) direction, it will be deflected in the $+x$ (or $-x$) direction. If the figures show examples of deflections through the Stern–Gerlach apparatus with the field gradient in the z direction in the plane of the paper, the deflection through a Stern–Gerlach apparatus with the field gradient in the x direction will be in a plane perpendicular to the plane of the paper. This actual 3D nature should be kept in mind in answering the questions. Notation: $|\uparrow\rangle_z$ and $|\downarrow\rangle_z$ represent the orthonormal eigenstates of \hat{S}_z (the z component of the spin angular momentum).

Question 1. A beam of neutral silver atoms propagating along the y direction (into the page) in spin state $(|\uparrow\rangle_z + |\downarrow\rangle_z)/\sqrt{2}$ is sent through a Stern–Gerlach apparatus with a vertical magnetic field gradient in the $-z$ direction. Sketch the pattern you expect to observe on a distant phosphor screen in the x - z plane when the atoms hit the screen. Explain your reasoning.

Question 2. A beam of neutral silver atoms propagating along the y direction (into the page) in spin state $|\uparrow\rangle_z$ is sent through a Stern–Gerlach apparatus with a horizontal magnetic field gradient in the $-x$ direction. Sketch the pattern you expect to observe on a distant phosphor screen in the x - z plane when the atoms hit the screen. Explain your reasoning.

Question 3. Chris sends silver atoms in an initial spin state $|\chi(0)\rangle = (|\uparrow\rangle_z + |\downarrow\rangle_z)/\sqrt{2}$ one at a time through a Stern–Gerlach apparatus with the magnetic field gradient in the negative x direction. He places a “down” detector in an appropriate location as shown in Fig. 9. What is the probability of the detector clicking when an atom exits the Stern–Gerlach apparatus with the magnetic field gradient in the negative x direction?

Question 4. Silver atoms in an initial spin state $|\chi(0)\rangle = |\uparrow\rangle_z$ pass one at a time through two Stern–Gerlach apparatuses

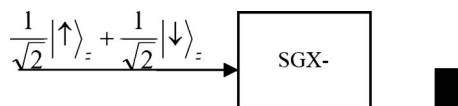

Fig. 9. Sketch of the Stern–Gerlach apparatus, initial spin state, and detector for Question 3.



Fig. 10. Sketch of the Stern–Gerlach apparatus, initial spin state, and detectors for Question 4.

tus with the magnetic field gradients as shown in Fig. 10. Two suitable detectors are placed, one after the first Stern–Gerlach apparatus and the second at the end to detect the atoms after they pass through both Stern–Gerlach apparatus. The atoms that do not register in the “up” detector at the end are collected for another experiment. Find the fraction of atoms that are detected in the up detector at the end and the normalized spin state of the atoms that are collected for another experiment.

Question 5. Suppose beam A consists of silver atoms in the state $|\chi(0)\rangle = (|\uparrow\rangle_z + |\downarrow\rangle_z)/\sqrt{2}$, and beam B is an unpolarized mixture in which half of the silver atoms are in state $|\uparrow\rangle_z$ and half are in state $|\downarrow\rangle_z$. Choose all of the following statements that are correct:

- (1) Beam A will not separate after passing through a Stern–Gerlach apparatus with the magnetic field gradient in the $\pm z$ direction.
 - (2) Beam B will split into two parts after passing through a Stern–Gerlach apparatus with the magnetic field gradient in the $\pm z$ direction.
 - (3) We can distinguish between beams A and B by passing each of them through a Stern–Gerlach apparatus with the magnetic field gradient in the $\pm x$ direction.
- (a) (1) only
 - (b) (2) only
 - (c) (1) and (2) only
 - (d) (2) and (3) only
 - (e) All of the above

Question 6. Sally sends silver atoms in state $|\uparrow\rangle_z$ through three Stern–Gerlach apparatus as shown in Fig. 11. Next to each detector, write down the probability that the detector clicks. The probability for the clicking of a detector refers to the probability that a particle entering the first Stern–Gerlach apparatus reaches that detector. Also, after each Stern–Gerlach apparatus, write the spin state Sally has prepared. Explain.

Question 7. Harry sends silver atoms all in the normalized spin state $|\chi\rangle = a|\uparrow\rangle_z + b|\downarrow\rangle_z$ through a Stern–Gerlach apparatus with the field gradient in the negative x -direction. He places an up detector as shown to block some silver atoms and collects the atoms coming out in the “lower channel” for a second experiment (see Fig. 12). What fraction of the initial silver atoms will be available for his second experiment? What is the spin state prepared for the second experiment? Show your work.

Question 8. Suppose you have a beam in the spin state $|\chi(0)\rangle = |\downarrow\rangle_z$ but you need to prepare the spin state $|\uparrow\rangle_z$ for



Fig. 11. Sketch of the Stern–Gerlach apparatus, initial spin state, and detectors for Question 6.



Fig. 12. Sketch of the Stern–Gerlach apparatus, initial spin state, and detector for Question 7.

your experiment. Could you use Stern–Gerlach devices and detectors to prepare the spin state $|\uparrow\rangle_z$? If yes, sketch your setup below and explain how it works. If not, explain why not.

Question 9. Suppose beam A consists of silver atoms in the state $(|\uparrow\rangle_z + |\downarrow\rangle_z)/\sqrt{2}$, and beam B consists of an unpolarized mixture in which half of the silver atoms are in state $|\uparrow\rangle_z$ and half are in state $|\downarrow\rangle_z$. Design an experiment with Stern–Gerlach apparatuses and detectors to differentiate these two beams. Sketch your experimental setup below and explain how it works.

¹D. Styer, “Common misconceptions regarding quantum mechanics,” *Am. J. Phys.* **64**, 31–34 (1996).

²P. Jolly, D. Zollman, S. Rebello, and A. Dimitrova, “Visualizing potential energy diagrams,” *Am. J. Phys.* **66** (1), 57–63 (1998).

³I. D. Johnston, K. Crawford, and P. R. Fletcher, “Student difficulties in learning quantum mechanics,” *Int. J. Sci. Educ.* **20**, 427–446 (1998).

⁴G. Ireson, “The quantum understanding of pre-university physics students,” *Phys. Educ.* **35** (1), 15–21 (2000).

⁵D. Zollman, S. Rebello, and K. Hogg, “Quantum physics for everyone: Hands-on activities integrated with technology,” *Am. J. Phys.* **70** (3), 252–259 (2002).

⁶M. Wittmann, R. Steinberg, and E. Redish, “Investigating student understanding of quantum physics: Spontaneous models of conductivity,” *Am. J. Phys.* **70** (3), 218–226 (2002).

⁷L. Bao and E. Redish, “Understanding probabilistic interpretations of physical systems: A prerequisite to learning quantum physics,” *Am. J. Phys.* **70** (3), 210–217 (2002).

⁸C. Singh, M. Belloni, and W. Christian, “Improving student’s understanding of quantum mechanics,” *Phys. Today* **59** (8), 43–49 (2006).

⁹L. D. Carr and S. B. McKagan, “Graduate quantum mechanics reform,” *Am. J. Phys.* **77** (4), 308–319 (2009).

¹⁰S. Y. Lin and C. Singh, “Categorization of quantum mechanics problems by professors and students,” *Eur. J. Phys.* **31**, 57–68 (2010).

¹¹A. Mason and C. Singh, “Do advanced physics students learn from their mistakes without explicit intervention?” *Am. J. Phys.* **78** (7), 760–767 (2010).

¹²*Research on Teaching and Learning of Quantum Mechanics*, papers pre-

sented at the 1999 National Association for Research in Science Teaching, (perg.phys.ksu.edu/papers/narst/).

¹³J. Hiller, I. Johnston, and D. Styer, *Quantum Mechanics Simulations, Consortium for Undergraduate Physics Software* (John Wiley and Sons, New York, 1995).

¹⁴C. Singh, “Transfer of learning in quantum mechanics,” in *Proceedings of Physics Education Research Conference*, edited by P. Heron, S. Franklin, and J. Marx, AIP Conf. Proc. No. 790 (AIP, Melville, NY, 2005), pp. 23–25.

¹⁵C. Singh, “Student difficulties with quantum mechanics formalism,” in *Proceedings of the Physics Education Research Conference*, edited by L. McCullough, P. Heron, and L. Hsu, AIP Conf. Proc. No. 883 (AIP, Melville, NY, 2007), pp. 185–25.

¹⁶C. Singh, “Student understanding of quantum mechanics,” *Am. J. Phys.* **69** (8), 885–896 (2001).

¹⁷C. Singh, “Interactive learning tutorials on quantum mechanics,” *Am. J. Phys.* **76** (4), 400–405 (2008).

¹⁸C. Singh, “Student understanding of quantum mechanics at the beginning of graduate instruction,” *Am. J. Phys.* **76** (3), 277–287 (2008).

¹⁹C. Singh, “Helping students learn quantum mechanics for quantum computing,” in *Proceedings of the Physics Education Research Conference*, edited by L. McCullough, P. Heron, and L. Hsu, AIP Conf. Proc. No. 883 (AIP, Melville, NY, 2007), pp. 42–45.

²⁰G. Zhu and C. Singh, “Students’ understanding of Stern-Gerlach experiment,” in *Proceedings of the Phys. Educ. Res. Conference*, edited by C. Henderson, M. Sabella, and C. Singh, AIP Conf. Proc. No. 1179 (AIP, Melville, NY, 2009), pp. 309–312.

²¹D. Schroeder and T. Moore, “A computer-simulated Stern-Gerlach laboratory,” *Am. J. Phys.* **61** (9), 798–805 (1993).

²²D. Styer, *The Strange World of Quantum Mechanics* (Cambridge U. P., Cambridge, 2000).

²³H. Batelaan, T. J. Gay, and J. J. Schwendingman, “Stern-Gerlach effect for electron beams,” *Phys. Rev. Lett.* **79**, 4517–4521 (1997).

²⁴R. P. Feynman, R. B. Leighton, and M. Sands, *The Feynman Lectures on Physics* (Addison-Wesley, Reading, MA, 1966), Vol. III.

²⁵M. Scully, W. Lamb, and A. Barut, “On the theory of the Stern-Gerlach apparatus,” *Found. Phys.* **17**, 575–583 (1987).

²⁶F. Weinert, “Wrong theory-right experiment: The significance of the Stern-Gerlach experiments,” *Stud. Hist. Philos. Mod. Phys.* **26**, 75–86 (1995).

²⁷L. McDermott, P. Shaffer, and Physics Education-Group, University of Washington, *Tutorials in Introductory Physics* (Prentice Hall, Upper Saddle River, NJ, 2002).

²⁸M. Chi, in *The Think Aloud Method: A Practical Guide to Modeling Cognitive Processes*, edited by M. W. Van Someren, Y. F. Barnard, and J. A. C. Sandberg (Academic, London, 1994), Chap. 1.

²⁹For example, see (www.opensourphysics.org) or (www.compadre.org); M. Belloni, W. Christian, and A. Cox, *Physlet Quantum Physics* (Pearson Prentice Hall, Upper Saddle River, NJ, 2006).

³⁰The original Spins program was written by Daniel Schroeder and Thomas Moore for the Macintosh and was ported to Java by David McIntyre (www.physics.orst.edu/mcintyre/ph425/spins/) and used as part of the Paradigms project. Both of these versions remain open source.